

# XK315A1GB-5

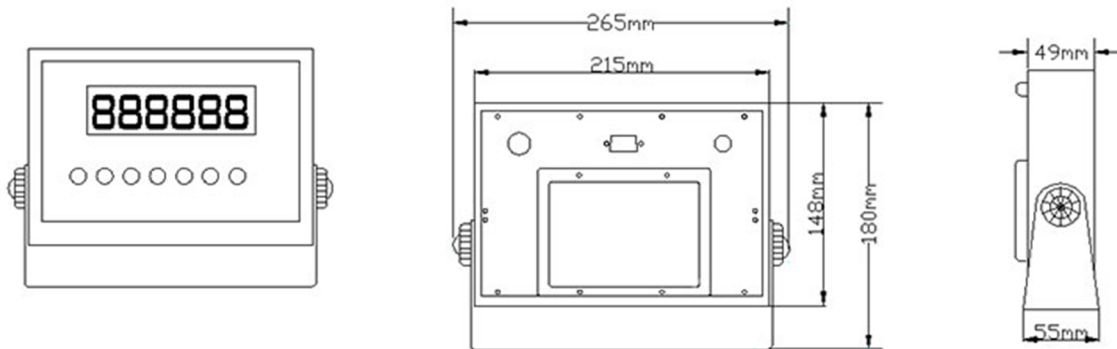

- Stainless steel square housing
- 0.8 inch green LED display
- AC 100V~240V
- Scope of application: electronic bench scales, floor scales, etc.

## Dimension(mm)



## Functions

- Principle of Triple Integral A/D Conversion
- 40 times/second A/D conversion speed
- Operating temperature: 0 °C -40 °C
- Storage and transportation temperature -25 °C -+55 °C
- Relative humidity ≤ 85% RH
- The battery is sufficient and can be used continuously for more than 30 hours
- Power saving mode optional
- Can be connected to 1-4 350 Ω or 1-8 700 Ω sensors
- Manual/automatic accumulation function
- Zero tracking range can be selected
- Filter time parameters can be set
- kg lb conversion
- RS-232 serial continuous output communication interface
- RS-485 long-distance communication interface can be added
- Increase display accuracy by 10x
- Animal scale function
- Peak holding function
- Counting function
- Print output function

## Specifications

Accuracy	III
Maximum number of divisions	nind =3000
excitation voltage	Uexc = 5v
Operating temperature range	-10℃ ~ +40℃
Load cell connection method	6wires
Maximum number of connected load cells	350O 4pcs / 700O 8pcs
Display	6 digits 20mm LED, expandable (X10) display
Weighing method	Gross / Net weight, manual totalization / automatic totalization
Serial port	RS232 continuous or command mode, optional RS485
Baud rate	1200/2400/4800/9600
Input voltage	220VAC 50/60Hz
Rechargeable battery	6V/4AH /6V/2.8AH
Storage and transportation temperature	-25℃ to +55℃
Relative humidity	10%-85% non-condensing